

veritas[®]
Scraping Plane



05P29.01

U.S. Pat. No. 7,444,750

The Veritas® Scraping Plane is used for the final levelling and smoothing of large, flat surfaces, even if they are highly figured, prior to applying a finish. Because it has the same configuration as a bench plane, it is comfortable to use for extended periods of time and the large sole ensures the surface of a workpiece is accurately flattened.

Given the fine cutting action of the scraping plane, it is used after the surface has been prepared as well as possible with a smoothing plane, not in place of the smoothing plane. What the scraping plane does replace, however, is the need for sanding prior to applying a finish. Because the scraping plane cuts the wood fibers rather than tears them, it will further bring out the wood grain, rather than mute it as sandpaper would.

This plane comes equipped with a 27/8" wide, 0.055" thick, high-carbon steel blade with the cutting edge ground at 45°. The beauty of our scraping plane is that you can either change the pitch of the blade or apply camber to it in order to obtain the best possible cutting action. The pitch, or blade angle, is variable from vertical to 25° forward. The more the blade is tilted forward, the more the depth of cut will increase. So, as the blade wears, you can tilt it forward, making it possible to keep scraping without having to stop and re-burnish the blade. And to further fine tune the depth of cut, you can apply camber to the blade. By slightly bowing or arching the blade, you also eliminate ridges in the work surface caused by blade corners.

An optional 0.125" thick A2 tool steel blade is also available for those who prefer an uncambered blade when working the more difficult wood grains.

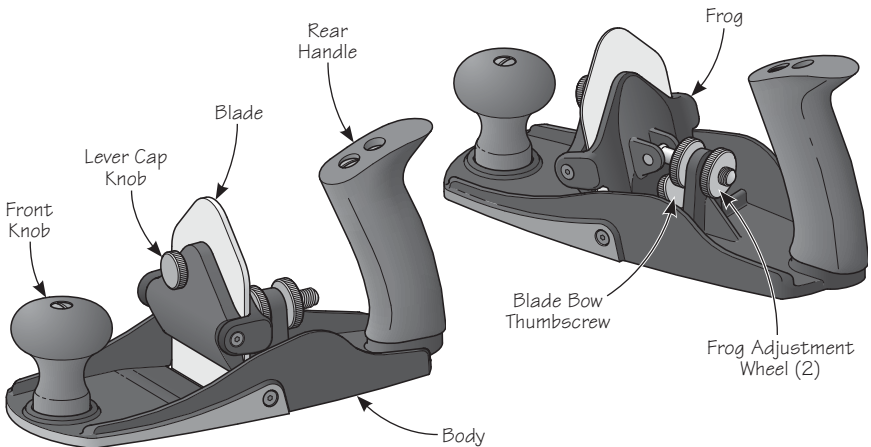

Figure 1: Scraping plane components.

Scraping

At first glance the scraping plane, or indeed even scraping itself, can appear odd or mysterious. Why would you scrape wood? Why is the blade angled forward? A closer look at where the actual cutting is taking place reveals the answers. The cutting geometry of the rolled edge on the scraping blade is not that much different from the cutting geometry of a bench plane with a well-set cap iron.

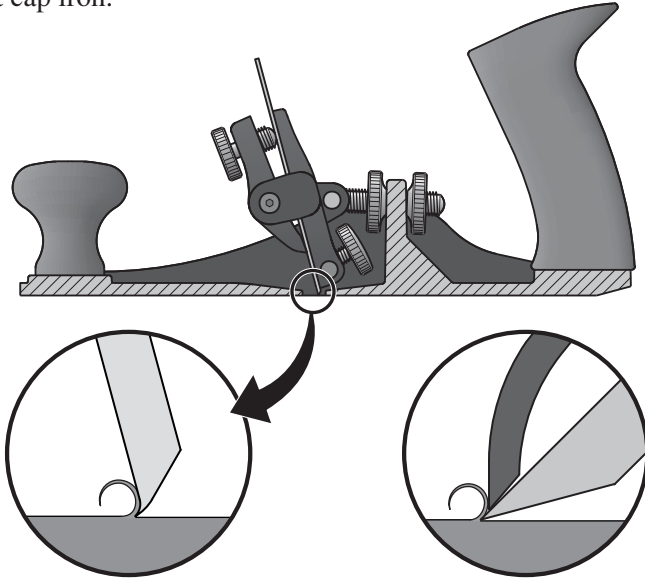

Figure 2a: Rolled edge of scraping blade.

Figure 2b: Bench plane with well-set cap iron.

Although the rolled edge on a scraping blade works much like a plane, the cutting action of a scraper is actually more like that of a high-angle smoothing plane (i.e., with a bed angle of 55° or 60° rather than the more common 45°). This means the wood shaving curls abruptly and falls right at the cutting edge, eliminating tear-out and allowing for the working of difficult grain patterns.

Sharpening

Sharpening the scraping blade is the most critical and difficult part of learning to use a scraping plane. Understanding how a scraper cuts (see above) and knowing what a properly burnished cutting edge looks and feels like are the key concerns when learning how to sharpen the blade.

The bevel angle on the blade is ground at 45° , rather than square as found on card (cabinet) scrapers. This makes it easy to burnish or deform the metal of the bevel into a relatively aggressive burr or hook.

The burnishing angle should be about 15°. An angle of 20° or more will result in too much scraping and not enough cutting (producing dust, not shavings). The higher angle also increases the likelihood of blade chatter. Smaller angles (closer to horizontal) may not cut at all as no cutting edge is introduced to the wood, or there may be no relief angle and the blade will just slide along the surface of the workpiece.

Step 1 – Preparation: This step is not necessary with a new blade. Before you start honing, the blade should be shaped to maintain a straight cutting edge and a 45° bevel. Hold the blade in a vise and use a 6" or 8" bastard cut mill file to prepare the blade. Check the bevel periodically with a straightedge and a protractor (or sliding bevel set to 45°) as you work. The Veritas Jointer/Edger (05M07.01) is ideal for this process. A bench-top belt sander with an 80x or 120x abrasive belt may also be used for this step.

Step 2 – Honing: Start with an 800x or 1000x stone to remove the marks from filing. Either an oil stone or water stone is suitable. Hold the blade as shown in **Figure 3** with the bevel flat against the stone. Stroke it back and forth, covering the whole stone. Check the bevel often to evaluate your progress. Continue until all file marks are gone. As shown in **Figure 4**, lap the face of the blade near the cutting edge to achieve the same finish as on the bevel. A sharp edge can only be achieved by creating two intersecting surfaces honed to the same degree. Using the same technique, transfer to a 4000x water stone or hard Arkansas oil stone to finish honing. The Veritas Power Sharpener or a bench-top belt sander with 320x (40μ) followed by 1200x (9μ) abrasive will provide the same results a bit faster.

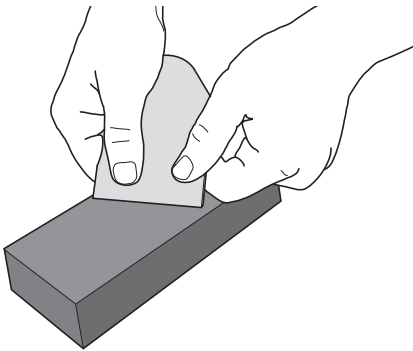

Figure 3: Honing.

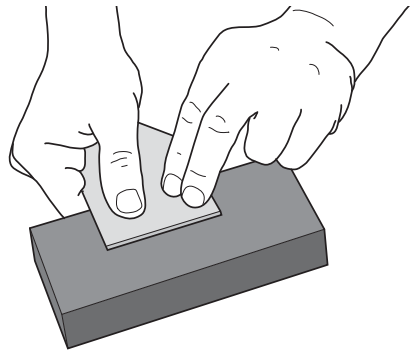

Figure 4: Lapping.

When sharpening a thick blade, we recommend that you round the corners of the blade to ensure they do not leave corner digs in the workpiece. (You may also do so on a thin blade, but it is unnecessary if you are going to bow the blade; see *Bow Adjustment* below). This is best accomplished by creating a small round at each end of the cutting edge as shown in **Figure 5** when first preparing the bevel with a file or belt sander. Work the rounded corners as well as the cutting edge at each successive stage of honing.

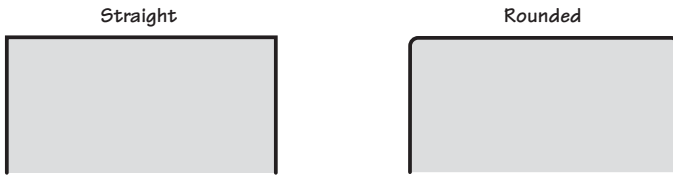

Figure 5: Rounding the corners of the blade.

Step 3 – Burnishing: With the blade held firmly in a vise, use a burnisher (the Veritas Tri-Burnisher 05K32.01 is well suited) to create a hook as shown in **Figure 6**. Use three or four even firm strokes across the entire edge of the blade at the same angle as the bevel. Raise the burnisher handle slightly and take three or four more strokes. Finish by taking three or four strokes with the burnisher 15° from horizontal as shown in **Figure 6**. The first few times you do this, sight against a reference tool such as a sliding bevel or engineer’s protractor set to the desired angle.

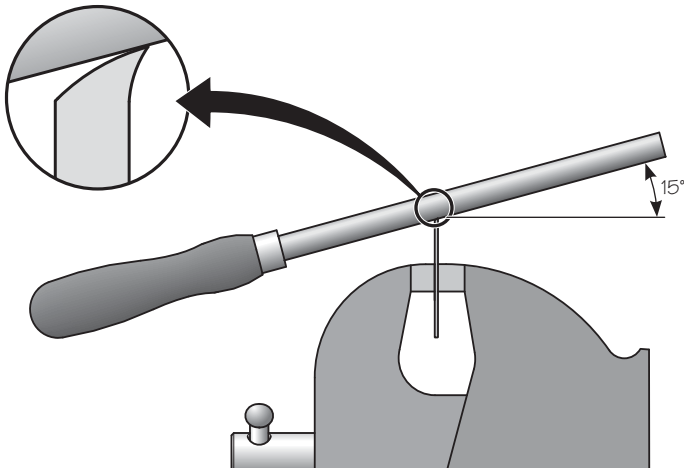

Figure 6: Burnishing.

Tip: Before burnishing, touch your fingertip to the side of your nose or behind your ear (two natural oil sources) and transfer that minute amount of oil to the blade. It reduces friction and avoids galling.

Toothed Blade Note: Sharpen and hone only the 45° bevel. **Do not** hone the face of the toothed blade, or you will damage the sharp points that actually do the cutting.

Blade Adjustment

With the blade prepared you are now ready to set up the plane. A blade burnished with a 15° angle will require setting the adjustable frog to about 5° forward of vertical using the frog adjustment wheels (see **Figure 7**). However, if your burnishing technique produces an angle other than 15° , you will have to determine the ideal frog setting. Use the scraping plane blade like a hand scraper to find the angle that produces the smoothest scraping action. Set the frog angle to approximately the same angle you established with hand scraping. Ensure that the blade bow thumbscrew is backed off such that it does not protrude beyond the frog face. Set the scraping plane on a smooth, flat and clean work surface. Insert the blade with the bevel facing the rear of the plane and the cutting edge resting on the work surface. Lightly hold the blade in place against the frog and tighten the lever cap knob (a quarter turn should be ample – **do not overtighten**) to secure the blade. The blade will now be flush with the sole.

To advance the blade, pick up the plane and pivot the frog forward $1/2^\circ$ or so. Just loosening the rear adjustment wheel and retightening the front wheel may provide enough movement. As the blade pivots forward, the cutting edge drops below the sole. Another technique you can use to set the initial blade projection is to place a single sheet of paper under the toe of the plane and set the cutting edge of the blade so that it is just resting on the work surface. You should not have to adjust the frog forward if you use this technique. Either way, the scraping plane is now ready for use. Take a few quick test cuts and fine tune the cut as required.

As the hook on the blade wears, you can continue to pivot the blade forward to re-establish the cutting action. Again, a shift of only $1/2^\circ$ or so may be all that is required. When making larger changes to the blade angle, be sure to reset the blade flush with the bottom to avoid moving the cutting edge too far below the sole of the plane. You may continue to adjust the blade forward to about 25° or so. At this point, if the plane is no longer producing shavings, the blade must be resharpened and the frog adjusted back to the 5° starting point.

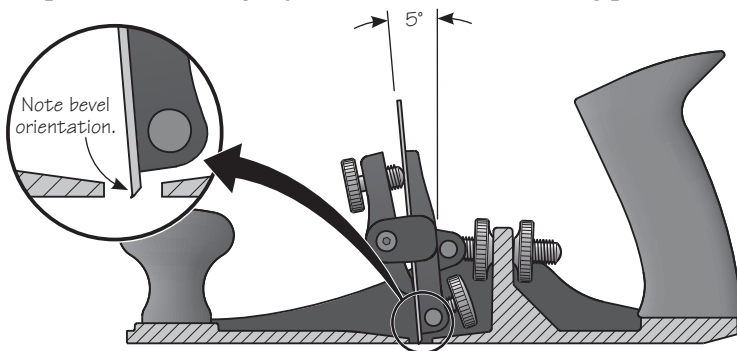

Figure 7: Frog adjustment.

Bow Adjustment

The above steps for blade adjustment will apply to both the thin (0.055") and the thick (0.125") blade. However, when using the thin blade, you also have the option of introducing a curve into the blade-cutting edge. With the thin blade installed as described above, turn the blade bow thumbscrew until it just contacts the blade. Sighting along the sole of the plane, begin to tighten the thumbscrew in small increments that will put a slight curve in the blade. This gives you a shallow bow, projecting in the middle to give you a fairly wide cutting area, with the corners not visible. Take a few test strokes and adjust the thumbscrew as desired. The more pressure applied with the blade bow thumbscrew, the more aggressive the cut.

Care and Maintenance

The body of this plane is ductile iron and comes treated with rust preventative. Remove this using a rag dampened with mineral spirits. Clean all machined surfaces.

We recommend that you initially, then periodically, apply a light coat of silicone-free paste wax to seal out moisture and prevent rusting (as well as act as a lubricant for smoother planing). Wipe off any wood dust from the surfaces that you will be waxing, apply a light wax coating, let dry, then buff with a clean cloth. At the same time, the solvents in the wax will remove any harmful oils left from your fingers that can lead to corrosion.

Keep in mind that typical paste wax contains silicone that, if transferred to your workpiece, could cause finishing problems such as "fish eyes". Before treating a plane with a sealant, wipe off any fingerprints with a cloth dampened with a small amount of light machine oil. Remove any residual oil; then apply the sealant to the plane's sole.

If storage conditions are damp or humid, the plane should, in addition to the treatment outlined above, be wrapped in a cloth or stored in a plane sack. This precaution will also guard against dings and scratches.

Every so often, clean all parts with a cloth dampened with a dab of light machine oil. The adjustment components (threaded shaft and wheels) will benefit from a light coat of oil to keep them working freely. For corroded plane bodies, we recommend you first remove the rust with a fine rust eraser, then treat as described above.

The bright finish on the brass components can be maintained as above. If a patina finish is preferred, simply leave the brass components unprotected until the desired level of oxidation has occurred, then apply a sealant. If you want to make them bright and shiny again, you can revitalize the surface with a brass polish.

The wooden knob and handle have a lacquer finish and should require nothing more than a wipe with a clean cloth from time to time.

Troubleshooting

Problem	Solution
Hard to push. Cut too aggressive.	Blade projects too far. Decrease angle of frog and/or back off blade bow thumbscrew.
A ridge or step is left on one side of the cut.	Blade is unevenly set (too low on one side). Re-clamp blade. Check that the blade cutting edge is square to the sides. Regrind as required.
Cutting action produces dust instead of shavings.	Blade is dull. Resharpener.
Scraped surface appears rough, covered with ridges and scratches.	Cutting edge not properly honed – scratches from coarse abrasive or file not removed in final stage of honing. Resharpener.
Blade will not cut.	Hook may be burnished too far. Re-hone and burnish.

Reference

The Complete Guide to Sharpening by Leonard Lee (The Taunton Press, Inc.).

Accessories

- 05P29.02** Replacement Thin (0.055") Scraping Plane Blade, High-Carbon Steel
- 05P29.03** Optional Thick (0.125") Scraping Plane Blade, A2 Tool Steel
- 05P29.04** Coarse Toothed Scraping Plane Blade (0.125"), A2 Tool Steel

veritas[®] Tools Inc.

814 Proctor Avenue 1090 Morrison Drive
Ogdensburg NY 13669-2205 Ottawa ON K2H 1C2
United States Canada

customerservice@veritastools.com

www.veritastools.com